

# CROSSOVER

*In a class by itself!*



*The world's first small  
laundry machines  
engineered to  
commercial standards.*

*Perfect for all  
on-premise laundry  
operations.*

** Wascomat**

# CROSSOVER

**Crossover is a revolutionary product engineered *exclusively* for commercial use. Washers are designed to last 15,000+ cycles—more than double the life of appliance-type top load and front load washers made for home use.**

- ✓ **Designed for three liquid chemical connections with clean pump signals.**
- ✓ **No oversudsing! Crossover will complete the cycle.**
- ✓ **CrossBalance technology keeps loads balanced.**
- ✓ **Built tough with top quality SKF bearings, triple seals, solid steel counterweights, and 8-point suspension system.**
- ✓ **All Crossover machines are soft-mount with pump drain for easy installation.**

Replace your appliance-type front loaders and top loaders with a true commercial laundry system from Wascomat.

*When Laundry Means Business!*



NON-METERED STACKING WASHER AND DRYER—(GAS HEAT DRYER)  
Model No. WDSGMM

NON-METERED STACKING WASHER AND DRYER—ELECTRIC Model No. WDSENM

## FEATURES AND BENEFITS

### WASHER

- ✓ 22+ lb capacity
- ✓ 15,000+ cycles durability
- ✓ 4 professional wash programs + 2 cycle options
- ✓ Top quality SKF bearings in heavy duty assembly
- ✓ 3 seals with 5 lips protect bearings
- ✓ Professional grade 8-point suspension
- ✓ Pump-drain standard
- ✓ Solid steel counterweights—no concrete

### DRYER

- ✓ 22+ lb capacity
- ✓ Built for 40,000 hours durability
- ✓ 7.5 cu ft drum

- ✓ Durable stainless steel fixed lint screen
- ✓ Axial airflow for efficiency
- ✓ Commercial grade components
- ✓ Extra large door opening
- ✓ Roller supported cylinder
- ✓ Heavy steel construction
- ✓ Tapered ribs bring load forward improving dryer performance.

## BEST CUSTOMER EXPERIENCE

### WASHER

- ✓ Superior oversuds and unbalance tolerance
- ✓ Large 15" door opening
- ✓ Heavy-duty door hinge
- ✓ 4 wash programs + 2 options
- ✓ High speed 300G max extraction

### DRYER

- ✓ Faster and more efficient drying
- ✓ Easy loading and unloading with the extra large door opening
- ✓ Large capacity tumbler can handle oversized loads
- ✓ Commercial grade components for maximum dependability and longer life

## MARKET READY DESIGN

- ✓ Space-saving 27" wide to minimize floor space
- ✓ Quiet operation
- ✓ Liquid chemicals are fully diluted with water



CROSSOVER OPL WASHER Model No. WHWF09810NM



CROSSOVER DRYER—GAS Model No. DAWF0GNM

CROSSOVER DRYER—ELECTRIC Model No. DAWF0ENM

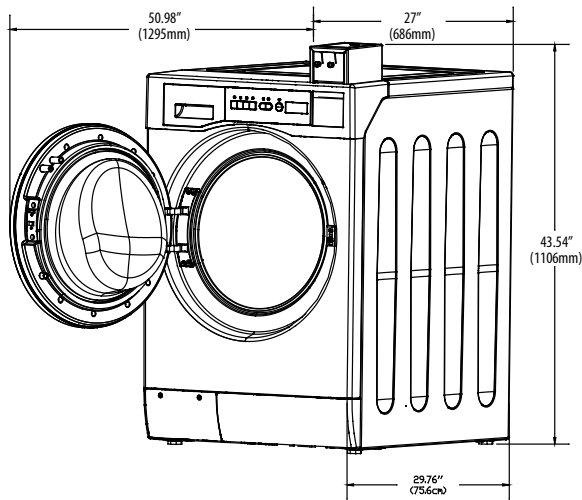

**CEE TIER III RATED**

6" base available

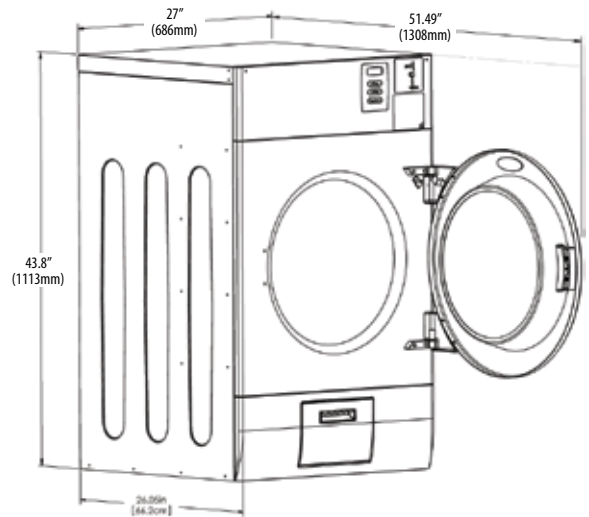

CROSSOVER WASHER SPECIFICATIONS	
<b>Model No.</b>	Non-Metered/Card Ready WHWF09810NM
<b>Motor</b>	Variable-speed, reversible, thermoprotected, high-efficiency, controlled induction
<b>Electrical Rating</b>	120 V/60 Hz / 1-phase
<b>Breaker Requirement</b>	15A
<b>Cylinder Volume</b>	3.5 cu ft (98 liters)
<b>Cylinder Diameter</b>	21 5/8 in (550 mm)
<b>Cylinder Depth</b>	18 1/4 in (464 mm)
<b>Wash Capacity</b>	22 lbs (10 kg)
<b>Door Opening</b>	15 in (380 mm)
<b>Wash Speed</b>	45 RPM
<b>Maximum RPM*</b>	1,000 RPM
<b>Maximum G-force*</b>	300 G
<b>Inlet Hose</b>	2 3/8 in (hoses included)
<b>Water Pressure</b>	10-90 psi (70-600 kPa)
<b>Drain Hose</b>	1 in (25.4 mm)
<b>Crated Weight</b>	314 lbs (142.7 kg)
<b>Uncrated Weight</b>	299 lbs (136 kg)
<b>Overall Dimensions</b>	W D H: 27 x 33 <sup>3</sup> / <sub>4</sub> x 39 <sup>3</sup> / <sub>4</sub> in w/o meter box W D H: 27 x 33 <sup>3</sup> / <sub>4</sub> x 43 <sup>1</sup> / <sub>2</sub> in w/meter box (W D H: 686 x 857 x 1010 mm w/o meter box) (W D H: 686 x 857 x 1106 mm w/meter box)

CROSSOVER DRYER SPECIFICATIONS	
<b>Model No.</b>	Non-Metered/Card Ready Gas DAWFOGNM
<b>Model No.</b>	Non-Metered/Card Ready Electric DAWFOENM
<b>Motor</b>	1/3 HP, thermoprotected
<b>Electrical Rating</b>	120V/60Hz
<b>Breaker/fuse Requirements (Gas Heat)</b>	15A
<b>Cylinder Volume</b>	7.5 cu ft (212 liters)
<b>Cylinder Diameter</b>	25 3/4 in (654 mm)
<b>Cylinder Depth</b>	24 in (609 mm)
<b>Capacity (Dry Weight)</b>	22 lbs (10 kg)
<b>Door Opening</b>	17 7/16 in (443 mm)
<b>Airflow</b>	220 cfm (340 m <sup>3</sup> /h)
<b>Gas Heating</b>	26,000 Btu/hr (6,550 kcal/hr)
<b>Gas Connection</b>	3/8 in MNPT
<b>Exhaust Connection</b>	4 in
<b>Crated Weight</b>	171 lbs (77.7 kg)
<b>Uncrated Weight</b>	151 lbs (68.6 kg)
<b>Overall Dimensions</b>	W D H: 27 x 29 7/8 x 44 1/4 in W D H: 685 x 759 x 1118 mm

\* NOTE: the correct measurement of extraction efficiency is G-force, not RPM. A higher RPM does not mean greater extraction, which depends on cylinder diameter.

# Laundrylux®

866.580.1010 ✓ [laundrylux.com/crossover](http://laundrylux.com/crossover)

Email inquiries to [crossover@laundrylux.com](mailto:crossover@laundrylux.com)

Technical questions? Call 516.371.0700

*Laundrylux offers a complete line of Electrolux professional and Wascomat commercial on-premise laundry equipment.*